

INTEGRATED TRANSFORMER, FEEDER, AND BREAKER PROTECTION: AN ECONOMIC AND RELIABLE SOLUTION FOR DISTRIBUTION SUBSTATIONS

Armando Guzmán, PE
Schweitzer Engineering
Laboratories, Inc.
2350 NE Hopkins Court
Pullman, WA 99163-5603
U.S.A.
(509) 332-1890

Mark G. Gutzmann, PE
Northern States Power Company
414 Nicollet Mall
Minneapolis, MN 55401
U.S.A.
(612) 330-6092

Pratap G. Mysore, PE
Northern States Power Company
Seventh Floor
414 Nicollet Mall
Minneapolis, MN 55401
U.S.A.
(612) 330-6774

ABSTRACT

New digital technology allows us to integrate transformer, feeder, and breaker protection in a single multifunction relay. This relay can also provide breaker reclosing, breaker control, and monitoring functions plus high resolution fault recording capabilities that simplify fault analysis. The new system has fewer components and offers a more efficient, economical, and reliable approach to substation protection, monitoring, and control.

This paper describes the application of a single microprocessor-based relay to protect a distribution substation consisting of a distribution transformer and two associated feeders at Northern States Power Company (NSP). The economic advantages of using a single relay allow users to afford a second relay for redundant protection.

INTRODUCTION

Traditionally, protection packages for distribution substations consisted of several discrete relays, each performing a single protective function, such as transformer, bus, and feeder protection. With the development of microprocessor-based relay designs, users could combine some of these discrete relays to provide individual power apparatus protection. Now, with further technologies, we can provide complete protection of all equipment in a distribution substation using a single multifunction relay. The diagram in Figure 1 illustrates this approach.

In this paper, we discuss the current practice of using individual devices for separate protection functions, then describe a new multifunction digital relay that provides complete protection for a distribution substation.

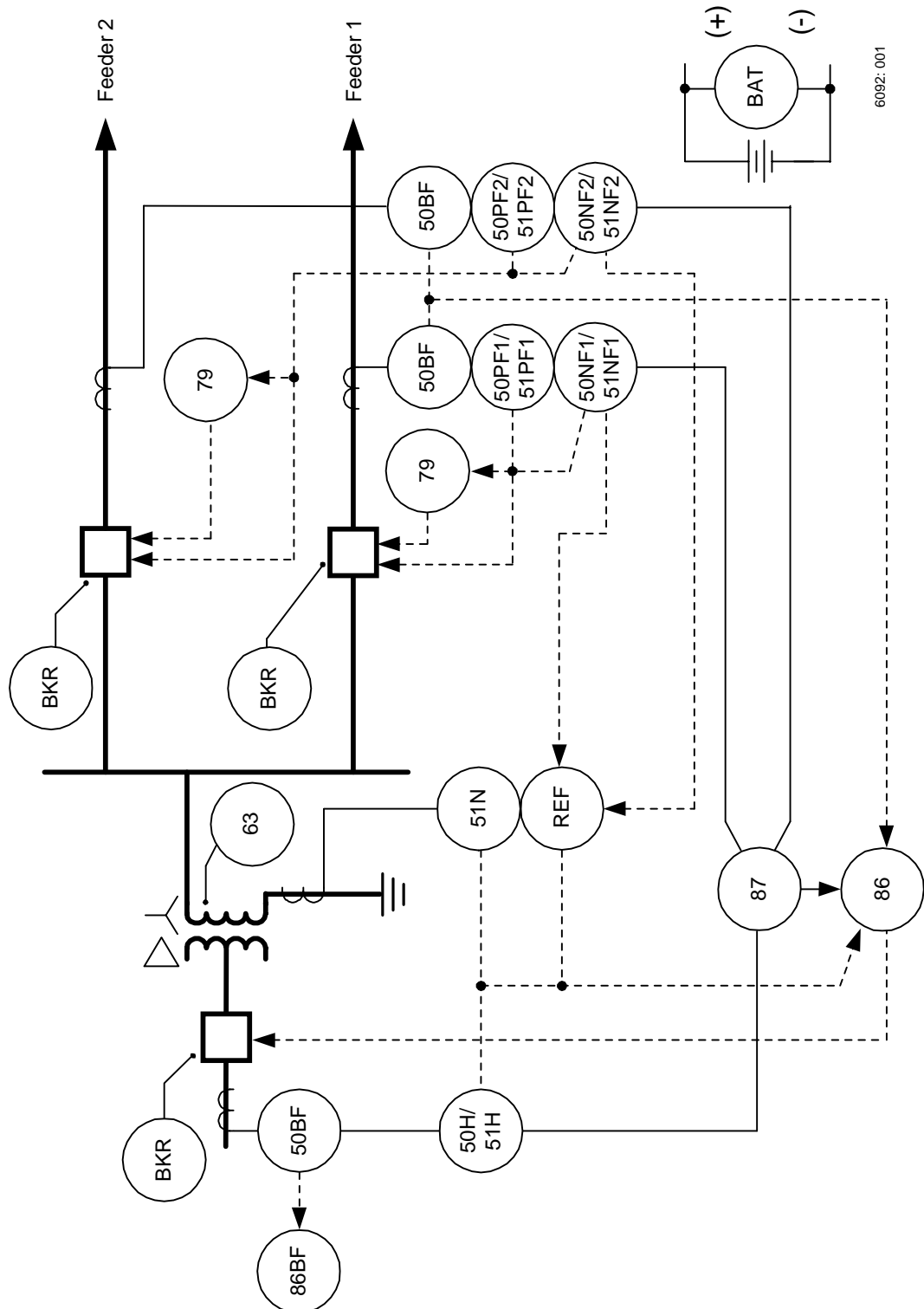

6092:001

Figure 1: A Single Multifunction Device Can Perform All of These Functions (With the Exception of the Lockout Relay, 86, and the Sudden Pressure Relay, 63).

The new relay includes the following functions depicted in Figure 1:

- Transformer and Bus Differential Protection, 87
- Transformer Backup Protection, 50H/51H
- Transformer Neutral Overcurrent Protection, 51N
- Restricted Earth Fault Protection, REF
- Phase and Ground Overcurrent Feeder Protection, 50PF/51PF/50NF/51NF
- Breaker Failure Protection, 50BF
- Breaker Reclosing Logic, 79
- Breaker Monitor, BKR
- Station DC Battery Monitor, BAT

We also discuss current differential, overcurrent, and breaker failure protection, then analyze ground faults in grounded transformer windings. Finally, we present the feeder automatic reclosing, breaker monitoring, battery monitoring, and fault recording capabilities.

EXISTING PROTECTION PRACTICE USING DISCRETE RELAYS

Protection of a 34.5 kV distribution substation at NSP consists of the following discrete relay protection packages:

Transformer Protection package with:

- Transformer Differential (87)
- Neutral Differential (REF or 87N)
- Neutral Overcurrent (51N)
- Backup Overcurrent (50H/51H)
- Sudden Pressure (63)

Feeder Protection package with:

- Three-Phase Overcurrent and Ground Overcurrent (50PF/51PF, 50NF/51NF)

Overcurrent relays on the low-voltage side of the transformer provide both distribution bus and feeder backup protection. In the absence of a low-side transformer breaker, the transformer differential zone includes the bus.

Reclosing relays installed on feeders provide an automatic restoration process following a temporary feeder fault.

NEW SYSTEM PROTECTION FUNCTIONS

The main protection functions of the new system include differential and overcurrent protection. The flexibility of the multifunction relay allows us to implement breaker failure protection for the three breakers in Figure 1. Let us look at the basic principles of these protection schemes.

Transformer and Bus Current Differential Protection

The transformer and bus current differential protection consists of three restrained and three unrestrained differential elements. Figure 2 shows the block diagram of the differential elements in a two-winding differential relay. The restrained differential element, 87R, uses the operating, IOP, and restraint, IRT, quantities obtained from the winding currents, IW1 and IW2. The relay scales each winding current according to its corresponding TAP setting and compensates the scaled currents according to the power transformer and current transformer connections. The operating quantity is the magnitude of the phasor sum of the compensated currents, IW1C and IW2C. The restraint quantity is half the scalar sum of the compensated currents.

The relay uses the operating and restraint quantities to obtain the relay characteristic (Figure 2) that has a minimum operating value and dual percentage slope. The minimum operating value, O87P, accommodates small differential currents caused by transformer exciting currents and by current transformer and relay errors. The first slope, SLP1, provides high sensitivity for small restraint currents; the second slope, SLP2, adds security for high external currents. The harmonic blocking element, 87BL, supervises the differential element and asserts when the second-harmonic or fifth-harmonic to fundamental ratio is greater than a settable harmonic percentage threshold [1]. The 87R element asserts if IOP and IRT are inside the operating region and the harmonic blocking element is deasserted.

The unrestrained differential element, 87U, compares the operating quantity against a settable threshold. If the operating quantity is greater than the unrestrained element threshold, U87P, the relay declares a tripping condition (87U element asserts).

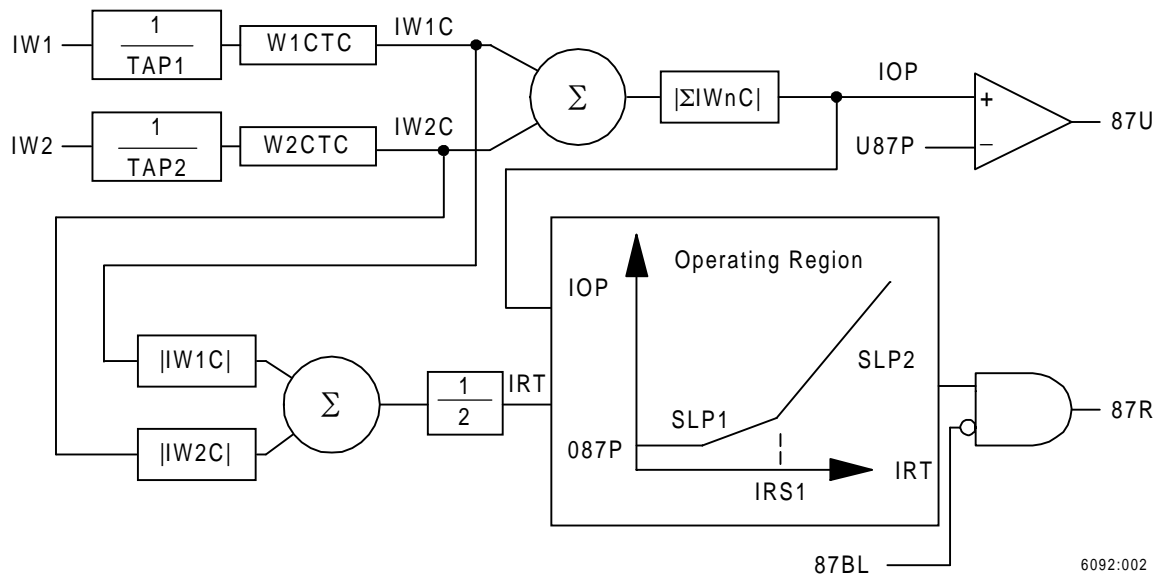

Figure 2: Restrained, 87R, and Unrestrained, 87U, Current Differential Elements for a Two-Winding Transformer.

Transformer Ground Fault Protection

First, we show what happens with the transformer neutral current when an internal ground fault occurs in the grounded winding. Then, we describe the benefits of using transformer Restricted Earth Fault and neutral overcurrent protection to detect this kind of fault.

Neutral Current For Transformer Ground Faults

Figure 3 shows a grounded transformer winding with a ground fault at the middle of the transformer winding.

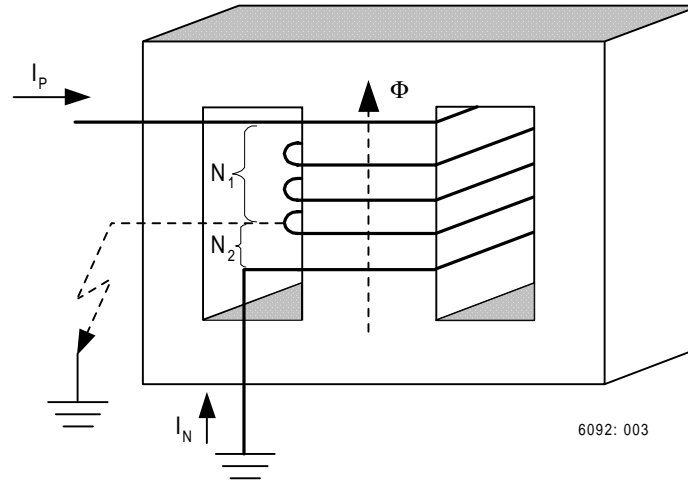

Figure 3: The Neutral Current, I_N , is Proportional to the Phase Current, I_P , for Ground Faults in a Grounded Transformer Winding.

When the ground fault occurs, the connection to ground, the short-circuited turns, N_2 , and the ground fault form a closed loop. Two coils share magnetic flux, Φ , during the ground fault condition. One coil consists of the healthy turns, N_1 ; the other one consists of the short-circuited turns. Gauss' law determines the magnetic flux inside the core:

$$\Phi = B \cdot A = \mu \cdot H \cdot A \quad \text{Equation 1}$$

Ampere's law determines the magnetic field intensity, H , inside the core:

$$H \cdot \ell = N_1 \cdot I_P \quad \text{Equation 2}$$

$$H \cdot \ell = N_2 \cdot I_N \quad \text{Equation 3}$$

where,

Φ = Magnetic Flux, Wb	B = Magnetic Flux Density, Wb/m ²
A = Core Area, m ²	H = Magnetic Field Intensity, (Amp-Turn)/m
μ = Permeability, H/m	ℓ = Core Length, m
N_2 = Short-Circuited Turns	N_1 = Healthy Turns
I_N = Neutral Current, A	I_P = Phase Current, A

With the above equations, we can determine the flux inside the two coils as a function of the currents, turns, permeability, and core dimensions:

Coil 1. Healthy Turns $\Phi = N_1 \cdot I_p \cdot \frac{\mu \cdot A}{\ell}$ Equation 4

Coil 2. Faulted Turns $\Phi = N_2 \cdot I_N \cdot \frac{\mu \cdot A}{\ell}$ Equation 5

From Equation 4 and Equation 5 we can express the magnetomotive forces of the two coils and the neutral current as follows:

$$N_1 \cdot I_p = N_2 \cdot I_N \quad \text{Equation 6}$$

$$I_N = \frac{N_1}{N_2} \cdot I_p \quad \text{Equation 7}$$

From Equation 7 we can see that the neutral current, I_N , depends on the turn ratio, N_1/N_2 , and on the phase current, I_p . Therefore, the neutral current exists if there is flux through the short-circuited coil. Further, note that the magnitude of current flow through I_N is substantial for lower winding faults where N_1/N_2 is high.

Benefits of Transformer Restricted Earth Fault (REF) and Neutral Overcurrent Protection

The following laboratory testing illustrates the benefits of REF and neutral overcurrent protection. As Figure 4 shows, we applied ground faults at different winding locations and measured both the primary current going into the transformer, I_p , and the current in the neutral connection, I_N . The current in the neutral connection is the current in the short-circuited turns. Due to high currents generated during the fault, the voltage source applied only 9 percent of the transformer nominal voltage. The transformer has 115/230 V nominal voltage and 5 kVA nominal capacity.

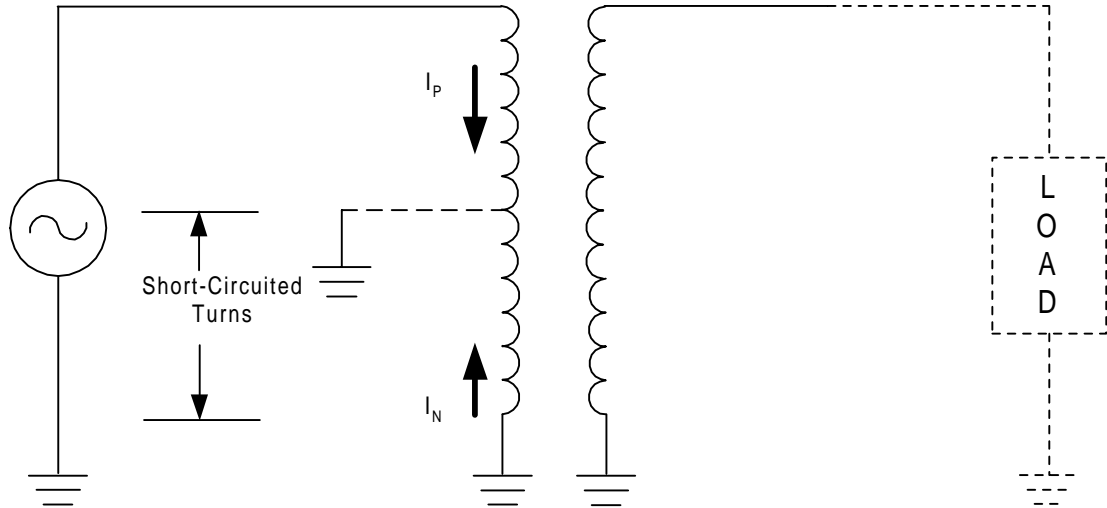

6092: 004

Figure 4: Transformer Ground Faults Produce High Neutral Currents.

Figure 5 shows primary and neutral currents for ground faults at different winding locations as percentages of nominal current. The primary current, the input current to the differential element, is small when the fault is close to the neutral terminal. In weak systems the primary current is even less than the current shown in Figure 5. The differential element will not see ground faults close to the transformer neutral. However, the neutral current is very substantial for these faults. REF and neutral overcurrent protection can detect ground faults close to the transformer neutral quickly and reliably.

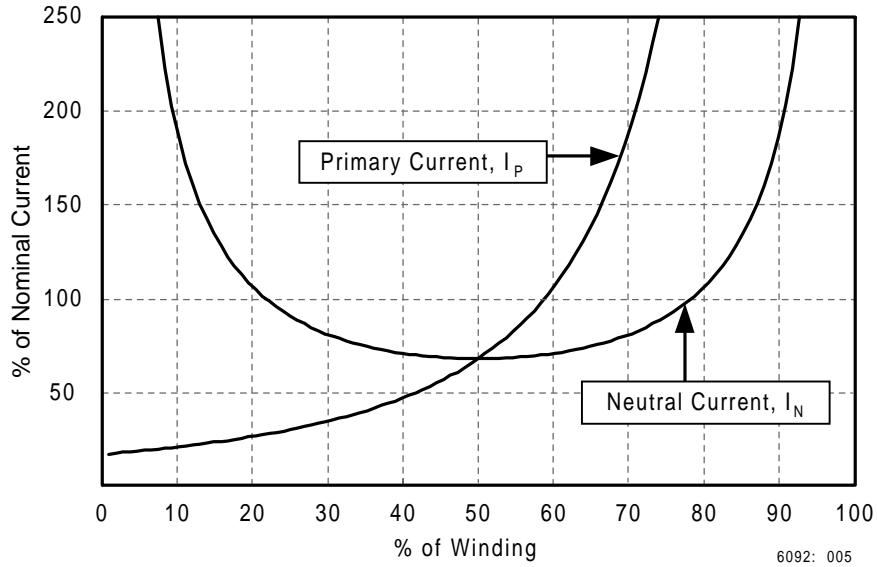

Figure 5: Current Magnitudes Depend Upon the Fault Winding Locations.

REF Protection Using a Directional Element

The REF element within the multifunction relay uses a current directional element, 32I, which measures the phase angle between the transformer neutral current and the winding residual current. This measurement determines if there is a fault inside or outside of the protected (restricted) zone. Figure 6 shows the current flows for an external fault condition. IX and IY are the currents going into the directional element. IX is the winding residual current, and IY is the neutral current. In this case IX and IY are 180 degrees out of phase, indicating an external fault condition.

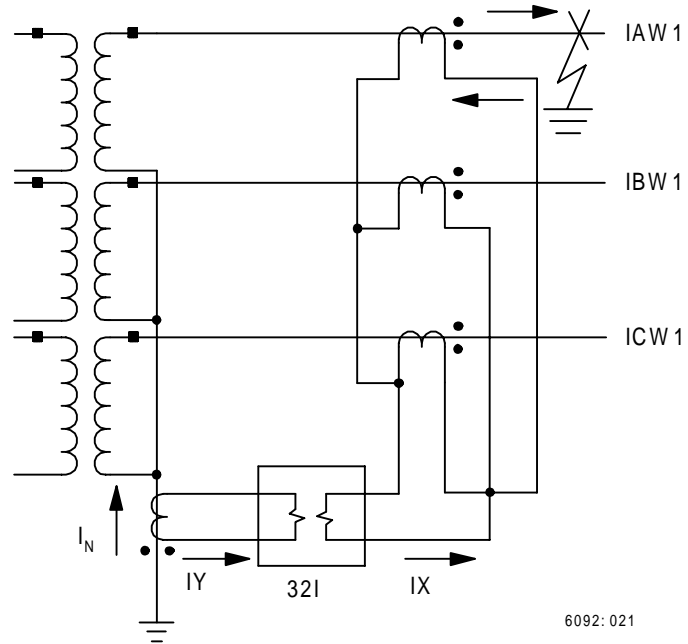

Figure 6: Current Directional Element (32I) for Ground Fault Protection in the Grounded Winding.

The directional element uses Equation 8 to calculate a torque-like quantity, T. If the torque is positive and greater than the positive threshold (Figure 7), the 32IF element asserts, indicating an internal fault condition. Torque is negative for external faults. If the torque value is less than the negative threshold, the fault declaration is reverse (out of the restricted zone), and 32IR asserts.

$$T = \text{Re}(IX \cdot IY^*) \quad \text{Equation 8}$$

where, Re = Real Operator and * = Complex Conjugate.

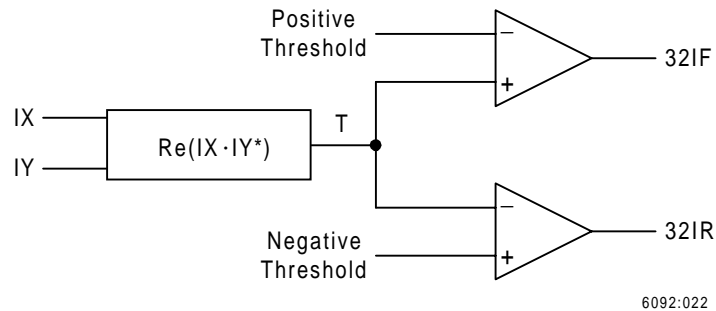

Figure 7: The 32I Directional Element Compares the Angle Between the Residual Current, IX, and the Neutral Current, IY, to Discriminate Between Internal and External Fault Conditions.

Transformer Neutral Overcurrent Protection

Transformer neutral overcurrent protection provides excellent ground fault protection to complement the differential protection. Neutral overcurrent protection may consist of an inverse-time overcurrent element or a definite-time overcurrent element. Transformer applications with grounded neutral have used this principle for many years.

Figure 8 shows the neutral transformer overcurrent protection, 51N. The overcurrent element serves two purposes: to detect faults close to the transformer neutral and to provide backup protection for external ground faults.

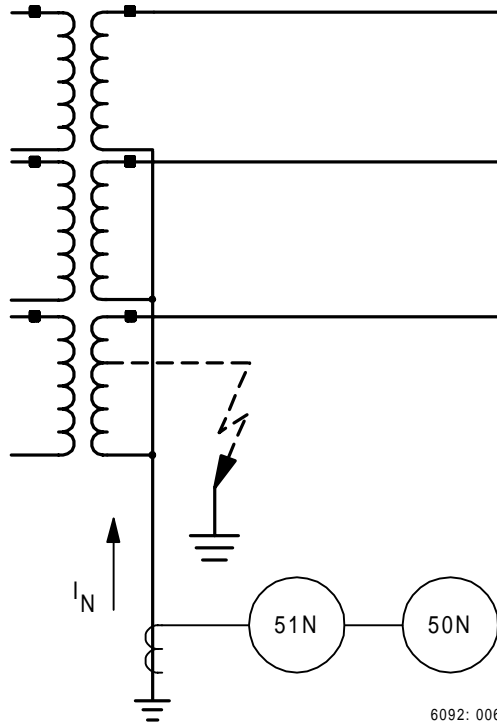

Figure 8: Neutral Transformer Overcurrent Protection Detects Faults Close to the Transformer Neutral.

A complementary approach is to include a definite-time overcurrent element with zero sequence current supervision from the distribution feeders, as Figure 9 shows. This approach, which does not need coordination with other overcurrent relays, provides fast ground fault detection within the restricted zone that includes the low-voltage transformer winding and the low-voltage substation bus. The drawback of this approach is that the zero-sequence supervision must be set above feeder current unbalance. Notice that this is not a limitation for the 32I element.

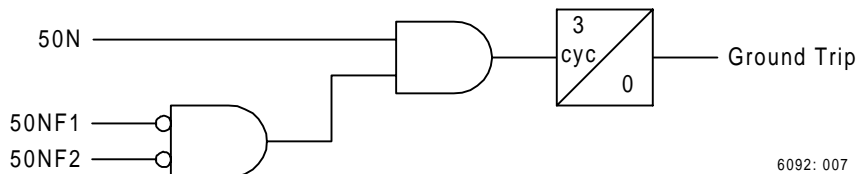

Figure 9: Definite-Time Neutral Overcurrent Element Provides Fast Ground Fault Detection.

Transformer Backup and Feeder Overcurrent Protection

The multifunction relay provides four sets of instantaneous and inverse-time overcurrent elements. Each set includes phase, negative-sequence, and residual ground overcurrent elements. We use the first set of phase elements for transformer backup protection. We use the

second and third sets of phase and residual ground elements for Feeder 1 and Feeder 2 primary protection. Figure 10 shows a simplified block diagram of the inverse-time, 51T, and the instantaneous, 50T, elements. Depending on the element operating current, the input to this block diagram is the magnitude of the phase, negative-sequence, or residual current. The logic for the 51T element emulates the electromechanical inverse-time overcurrent relay characteristic [2]. The inverse-time element calculates the accumulated travel distance, θ_{NEW} , from the multiple, M , and the previous travel distance, θ_{OLD} . The multiple, M , is the ratio of the current magnitude, $|I|$, to the pickup value, 51PU. If the accumulated travel distance, θ_{NEW} , exceeds the total travel distance, $\theta(51TD)$, where $\theta(51TD)$ is a function of the time dial setting, 51TD, the 51T element asserts. The lower part of Figure 10 shows a simple instantaneous overcurrent element, 50T, which asserts if the current magnitude exceeds the pickup value, 50PU.

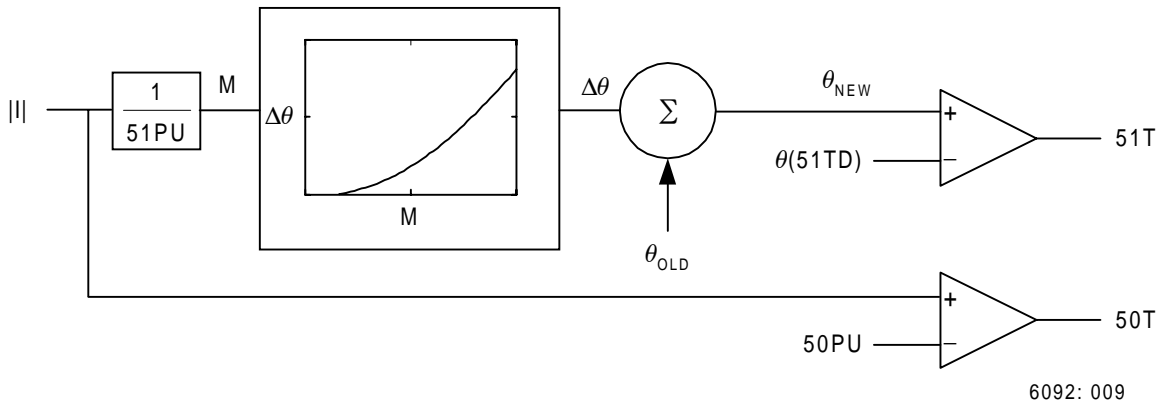

Figure 10: Block Diagram Showing Inverse-Time and Instantaneous Overcurrent Elements.

Breaker Failure Protection

Figure 11 shows the breaker failure protection scheme implemented using the relay general purpose instantaneous overcurrent elements and logic. The scheme provides breaker failure logic for interrupting fault currents and retripping the breaker. The breaker failure timer, BFT, starts timing after the breaker failure initiation input, BFI, asserts. The logic checks if the phase or residual instantaneous overcurrent elements, 50BFP or 50BFN, are asserted after the breaker failure timer expires. If the overcurrent elements are asserted after the breaker failure timer times out, the breaker failure trip element, BF, asserts and activates the lockout relay, 86BF. The logic also includes breaker retrip, RT, after the breaker failure initiation condition. The retrip logic gives the breaker another chance to trip, avoiding the tripping of additional breakers. The delay, RTD, in the retrip logic allows us to detect problems in the primary breaker coil.

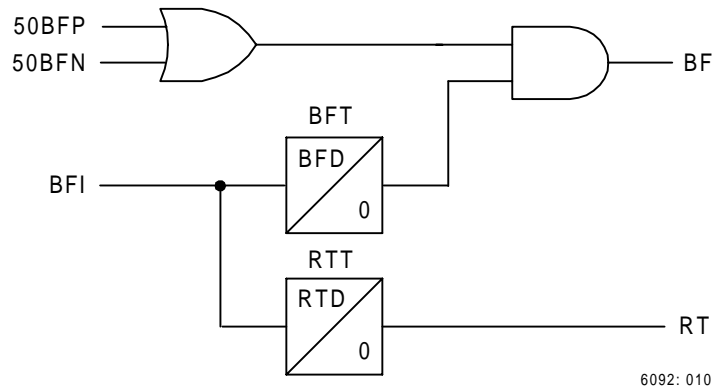

Figure 11: Breaker Failure Logic for Interrupting Fault Currents and Breaker Retrip.

NEW SYSTEM CONTROL, MONITORING, AND RECORDING FUNCTIONS

Automatic Reclosing

The system includes automatic reclosing, 79, capabilities for each of the feeders shown in Figure 1. The reclosing scheme provides one-shot reclosing following a feeder trip. Figure 12 shows the reclosing logic that we used for each of the distribution feeders. The logic inputs include reclose initiation, 79RI; reclose cancel, 79RC; breaker status, 52A; reclose block, 79BLK; and reclose unblock, 79UNBLK. The 79T timer provides the reclosing time delay, 79D. The reclosing relay starts timing if the 79RI input asserts, there are no canceling or blocking conditions, and the breaker is open. The 79CLS output asserts after the timer, 79T, times out. This output then goes into the closing input, CL, of the close logic shown in Figure 13. The close logic includes a close failure timer, CFT, for alarming purposes. If the breaker does not close within the CFD time (the CLS bit asserts for a longer time than the CFT timer pick-up value), the close logic asserts the CFT bit, indicating problems in the breaker closing circuit or mechanism.

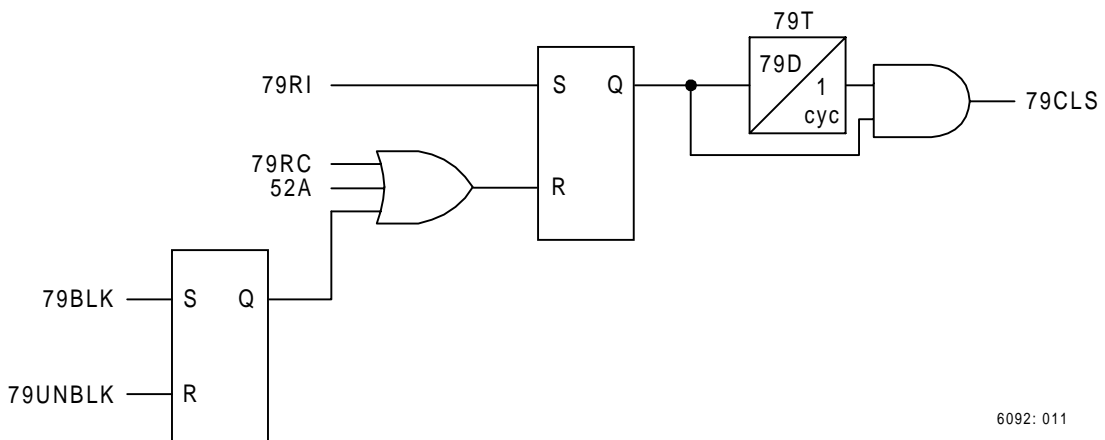
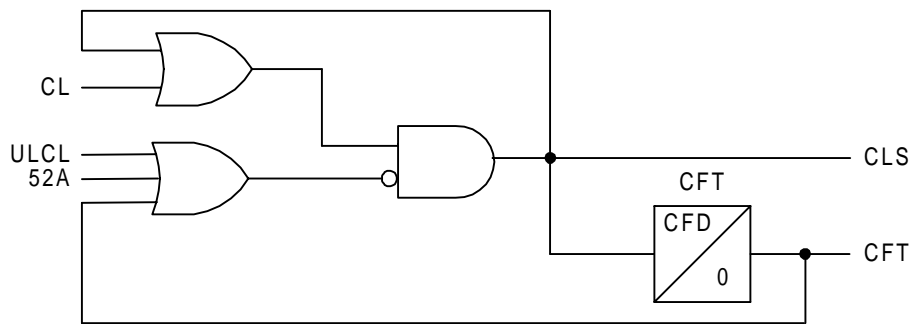

Figure 12: Reclosing Scheme Providing One-Shot Reclosing Following a Feeder Trip.



6092: 012

Figure 13: Close Logic With a Close Failure Alarm to Indicate Problems in the Breaker Closing Circuit or Mechanism.

Breaker Monitoring

Breaker Contact Wear

The relay includes algorithms for breaker contact wear monitoring that help in scheduling breaker maintenance. This monitor requires the input of the breaker contact wear curve shown in Figure 14 [3]. This curve has three regions, 1, 2, and 3, allowing you to tailor the curve according to the breaker in the particular application. The first region is intended for low currents, the second region for medium currents, and the third region for high currents. This curve flexibility accommodates mechanical wear due to low-current breaker interruptions and electrical wear due to medium and high currents. In this application the relay monitors the three substation breakers shown in Figure 1.

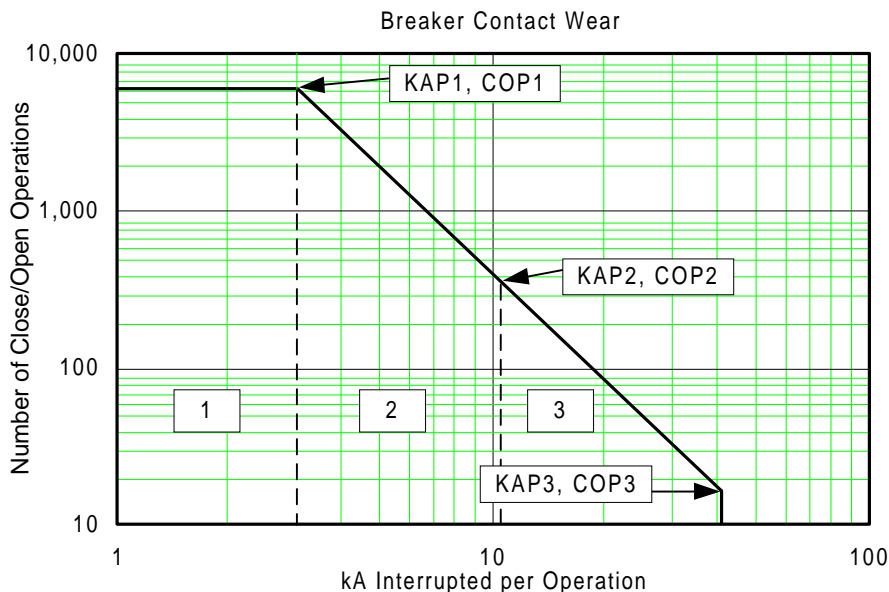

6092: 013

Figure 14: Breaker Contact Wear Curve Shows Low-, Medium- and High-Current Interruption Regions.

The monitor calculates the incremental wear according to the following expression:

$$\Delta\text{Wear} = \frac{100}{K_n \cdot I^\alpha} \quad \text{Equation 9}$$

where K_n and α_n are constants that depend on the number of Close/Open operations, COPn, that the breaker allows when interrupting KAPn current values. The variable, n, represents regions 1, 2, or 3 in Figure 14.

Equation 9 represents the equation of a straight line in a log-log plot. The monitor allows us to program three regions; we need one equation per region. Each region has its corresponding K and α constants. The monitor calculates these constants from KAPn and COPn as Table 1 shows:

Table 1: α and K Constants for the Three Regions in Figure 14

Region 1	Region 2	Region 3
$\alpha_1 = 0$	$\alpha_2 = \frac{\log_{10}(\text{COP1}/\text{COP2})}{\log_{10}(\text{KAP1}/\text{KAP2})}$	$\alpha_3 = \frac{\log_{10}(\text{COP2}/\text{COP3})}{\log_{10}(\text{KAP2}/\text{KAP3})}$
$K_1 = \text{COP1}$	$K_2 = \frac{\text{COP1}}{\text{KAP1}^{\alpha_2}}$	$K_3 = \frac{\text{COP2}}{\text{KAP2}^{\alpha_3}}$

where KAP1, COP1, KAP2, COP2, KAP3, and COP3 are the points indicated in Figure 14. Figure 15 shows the simplified breaker wear algorithm. The breaker monitor tracks the percentage of wear on the breaker contact, incrementing this percentage 1.5 cycles after the BKMON input asserts. This input, in parallel with the trip coil, asserts for every breaker open operation. The logic compares the new wear percentage against the 100 percent threshold, and if the wear percentage exceeds the threshold, the monitor asserts the BCW bit for alarming and/or closing supervision purposes.

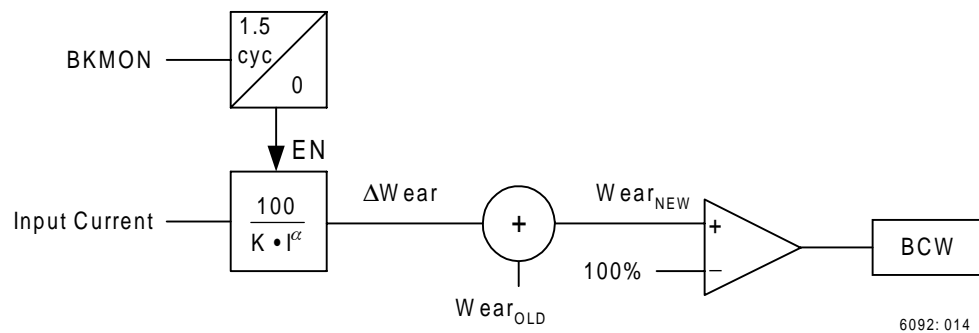
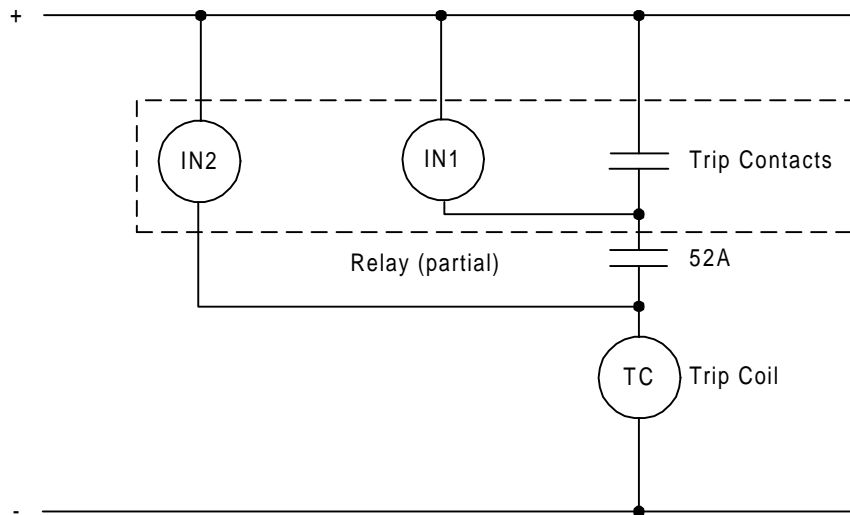

Figure 15: Breaker Wear Monitor Calculates the New Wear Percentage One-and-a-Half Cycles After the BKMON Asserts to Keep Track of the Breaker Contact Wear.

Trip Circuit Monitor

References [4] and [5] discuss simple logic to monitor the breaker trip circuit during open and close conditions. This logic uses two digital inputs to accomplish this monitoring. Figure 16 shows the dc connection for the trip circuit monitor. The logic detects loss of dc, trip coil open, and wiring problems. Table 2 summarizes the different trip coil path conditions and relay input status.



6092: 015

Figure 16: DC Connections for Trip Circuit Monitoring.

Table 2: Trip Coil Path Conditions and Relay Input Status

Breaker Position	IN1	IN2	Trip Path Condition
Open	0	0	Loss of Tripping DC or Coil Open
Open	0	1	Trip Path OK
Closed	0	0	Loss of Tripping DC or Coil Open
Closed	0	1	Trip Coil OK, Trip Wiring Bad
Closed	1	0	Wiring Error or 52a Failure
Closed	1	1	Trip Path OK

Legend: 0 ≡ Input Deasserted; 1 ≡ Input Asserted

Figure 17 shows the logic for detecting the conditions shown in Table 2. The logic includes a delay to accommodate the open/close auxiliary contact status transitions. You can use the output of this logic for alarming and/or supervising conditions.

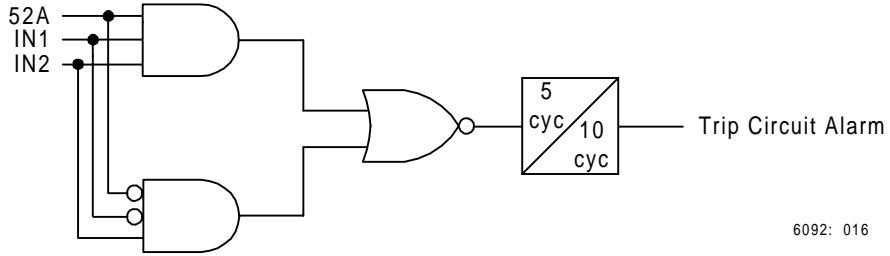

Figure 17: Logic for Detecting Problems in the Breaker Trip Coil.

Battery Monitoring

The relay includes one dc battery voltage monitor to detect under-/overvoltage conditions in the dc voltage applied to it. The relay also provides oscillographic display of the dc voltage at 3.84 kHz for diagnostic analysis such as dc ripple monitoring. Figure 18 shows the healthy, warning, and failure zones that the monitor detects. Through use of these warning zones, the monitor can detect momentary fluctuations in dc voltage supply during high dc current demand conditions or problems in the station battery or charger system. Normal operation is between DC2 and DC3. The monitor causes the relay to display a warning condition if dc voltage rises into the range between DC3 and DC4 or falls into the range between DC1 and DC2. Should dc voltage either exceed DC4 or fall below DC1, the monitor indicates a dc voltage, Vdc, failure condition. Figure 19 shows the logic for detecting abnormal operating conditions.

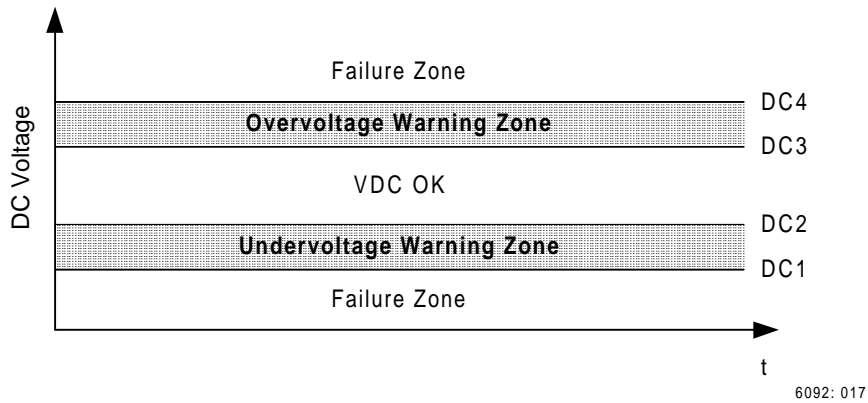

Figure 18: Through Use of Warning and Failure Zones, the Battery Monitor Can Detect Problems in the Station Battery or Charger System.

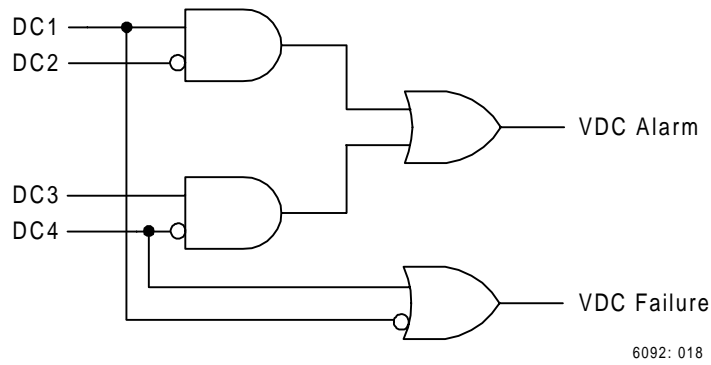

Figure 19: Logic Detects Alarming or Failure Conditions in the Station DC Battery.

Fault Recording

The system has powerful data acquisition that samples the current channels at 3.84 kHz and stores up to seven one-second records in nonvolatile memory. It integrates oscillographic information of the whole substation, simplifying fault analysis. Complementary software adds the ability to display oscillograms and to convert the recorded file to ASCII COMTRADE format. With testing equipment, the COMTRADE format allows playback of recorded data. Figure 20 shows the inrush current conditions upon transformer energization, and Figure 21 shows the excitation current during 150 percent transformer overvoltage conditions.

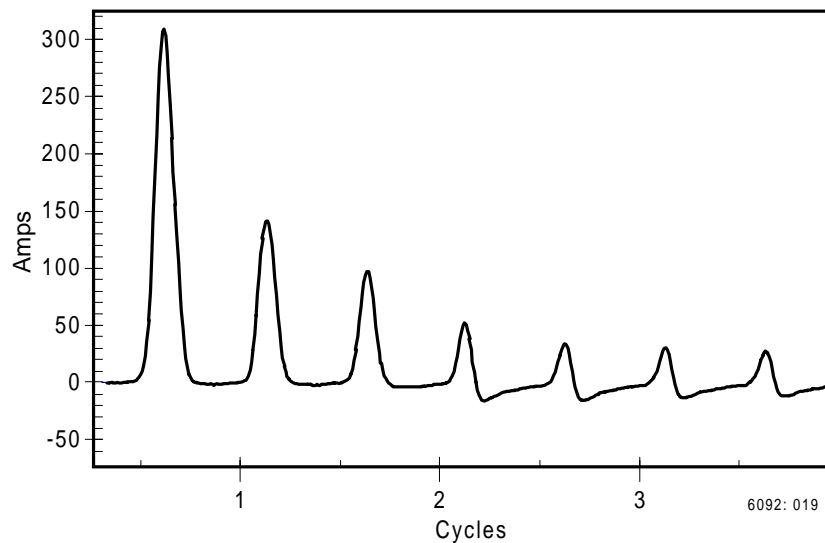

Figure 20: Inrush Current Upon Energization of a Laboratory Transformer.

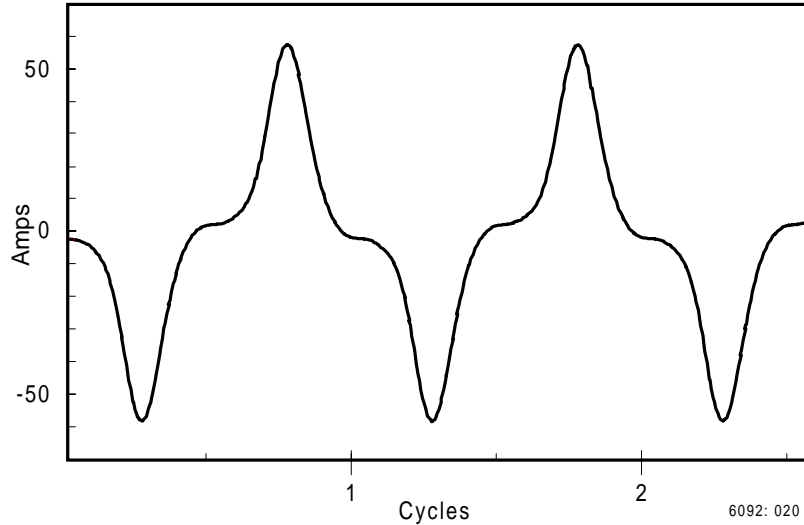

Figure 21: Exciting Current During 150% Transformer Overvoltage Condition.

CONCLUSIONS

The multifunction relay application described in this paper provides the protection functions that small distribution substations need. Additional control and monitoring functions make the whole system more economical and reliable than solutions that use separate devices for each power system apparatus.

This approach, or similar approaches, could be very useful in future substation designs. Easy and economical integration to power system supervisory control and data acquisition (SCADA) also make it an integrated solution for distribution substations.

REFERENCES

- [1] S. E. Zocholl, A. Guzmán, and D. Hou, "Transformer Modeling as Applied to Differential Protection," 22nd Annual Western Protective Relay Conference, Spokane, WA, October 24–26, 1995.
- [2] S. E. Zocholl and G. Benmouyal, "Testing Dynamic Characteristics of Overcurrent Relays," 47th Annual Georgia Tech Protective Relaying Conference, Atlanta, GA, April 28–30, 1993.
- [3] Siemens, "Instructions, Installation, Adjustment, Maintenance, Type SPS2-15.5, 25.8, 38, 48.3, and 72.5 Gas Circuit Breaker Spring Operating Mechanism," PB 3638-01.
- [4] J. B. Roberts, A. Guzmán, and L. Gross, "Making Trip Circuit Monitor Logic With SELOGIC[®] Control Equations," SEL Application Guide AG96-08.
- [5] J. B. Roberts and T. J. Lee, "Measuring and Improving DC Control Circuits," 25th Annual Western Protective Relay Conference, Spokane, WA, October 13–15, 1998.

BIOGRAPHIES

Armando Guzmán received a bachelor's degree with honors in electrical engineering from Guadalajara Autonomous University (UAG), Mexico, in 1979. He received a diploma in fiber-optics engineering from Monterrey Institute of Technology and Advanced Studies (ITESM), Mexico, in 1990. He served as regional supervisor of the Protection Department in the Western Transmission Region of Federal Electricity Commission (the electrical utility company of Mexico) for 13 years. He lectured at the Guadalajara Autonomous University in power system protection. Since 1993 he has been with Schweitzer Engineering Laboratories, Inc., Pullman, Washington, where he is presently a research engineer. He is a member of IEEE and has authored and coauthored several technical papers.

Mark G. Gutzmann received his bachelor's degree in electrical engineering from the University of Minnesota Institute of Technology in 1990. His utility experience began while he was a student engineer in the Substation Engineering group at Northern States Power Company in 1988. He began his professional career in 1991 as a computer engineer at the Prairie Island Nuclear Generating Plant. In 1994 he returned to the Substation Engineering group at Northern States Power Company as a protection engineer. He is presently a senior engineer in that same group. Gutzmann is a Professional Engineer registered in the state of Minnesota.

Pratap G. Mysore received his bachelor and master degrees in electrical engineering from Indian Institute of Science, India, in 1974 and 1976, respectively. He began his professional career in 1976 in India with Tata Electric Companies, an electric utility, as a relay engineer. From 1979 until 1987, he was with Brown Boveri Corporation, now ABB, in relay R&D and manufacturing divisions in India. Since 1987 he has been with Northern States Power Company, where he is presently a consulting engineer in the Substation Engineering group. Mysore is actively involved in working groups of the IEEE Power Systems Relaying Committee. He is a member of the substations protection subcommittee and vice chair of the shunt reactor protection working group. Mysore is a Professional Engineer registered in the state of Minnesota.

Printed in USA
20000323